

Mechanical Engineering Department

University of New Mexico

Ph.D. Qualifying Examination

Controls Section

Spring 2013

INSTRUCTIONS:

- Closed Book
- There are 3 problems worth a total of 100 points
- 2 Hours
- Calculator allowed
- You ***MUST*** show work to get credit.

Problem 1. (30 points) Determine the transfer function of output to input C/R for the single input system shown.

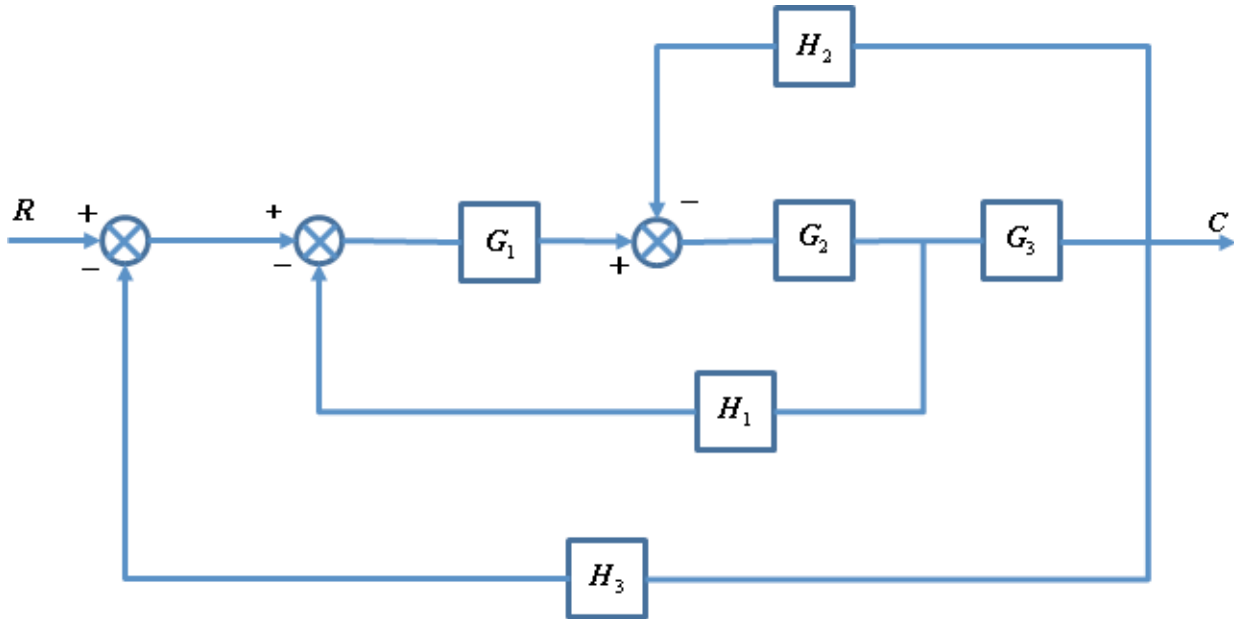

Problem 2. (30 points) Use the Laplace Transform method to determine the total response of the system described by:

$$2\ddot{x} + 10\dot{x} + 8x = 15u_s(t)$$

where $u_s(t)$ is the unit step function for the initial conditions: $x(0) = 2$ and $\dot{x}(0) = 5$. A table of Laplace transforms has been provided for your use.

Table of Laplace Transforms

$f(t) = \mathcal{L}^{-1}\{F(s)\}$	$F(s) = \mathcal{L}\{f(t)\}$	$f(t) = \mathcal{L}^{-1}\{F(s)\}$	$F(s) = \mathcal{L}\{f(t)\}$
1. 1	$\frac{1}{s}$	2. e^{at}	$\frac{1}{s-a}$
3. $t^n, n=1,2,3,\dots$	$\frac{n!}{s^{n+1}}$	4. $t^p, p > -1$	$\frac{\Gamma(p+1)}{s^{p+1}}$
5. \sqrt{t}	$\frac{\sqrt{\pi}}{2s^{\frac{3}{2}}}$	6. $t^{n-\frac{1}{2}}, n=1,2,3,\dots$	$\frac{1 \cdot 3 \cdot 5 \cdots (2n-1)\sqrt{\pi}}{2^n s^{n+\frac{1}{2}}}$
7. $\sin(at)$	$\frac{a}{s^2+a^2}$	8. $\cos(at)$	$\frac{s}{s^2+a^2}$
9. $t \sin(at)$	$\frac{2as}{(s^2+a^2)^2}$	10. $t \cos(at)$	$\frac{s^2-a^2}{(s^2+a^2)^2}$
11. $\sin(at) - at \cos(at)$	$\frac{2a^3}{(s^2+a^2)^2}$	12. $\sin(at) + at \cos(at)$	$\frac{2as^2}{(s^2+a^2)^2}$
13. $\cos(at) - at \sin(at)$	$\frac{s(s^2-a^2)}{(s^2+a^2)^2}$	14. $\cos(at) + at \sin(at)$	$\frac{s(s^2+3a^2)}{(s^2+a^2)^2}$
15. $\sin(at+b)$	$\frac{s \sin(b) + a \cos(b)}{s^2+a^2}$	16. $\cos(at+b)$	$\frac{s \cos(b) - a \sin(b)}{s^2+a^2}$
17. $\sinh(at)$	$\frac{a}{s^2-a^2}$	18. $\cosh(at)$	$\frac{s}{s^2-a^2}$
19. $e^{at} \sin(bt)$	$\frac{b}{(s-a)^2+b^2}$	20. $e^{at} \cos(bt)$	$\frac{s-a}{(s-a)^2+b^2}$
21. $e^{at} \sinh(bt)$	$\frac{b}{(s-a)^2-b^2}$	22. $e^{at} \cosh(bt)$	$\frac{s-a}{(s-a)^2-b^2}$
23. $t^n e^{at}, n=1,2,3,\dots$	$\frac{n!}{(s-a)^{n+1}}$	24. $f(ct)$	$\frac{1}{c} F\left(\frac{s}{c}\right)$
25. $u_c(t) = u(t-c)$ Heaviside Function	$\frac{e^{-cs}}{s}$	26. $\delta(t-c)$ Dirac Delta Function	e^{-cs}
27. $u_c(t) f(t-c)$	$e^{-cs} F(s)$	28. $u_c(t) g(t)$	$e^{-cs} \mathcal{L}\{g(t+c)\}$
29. $e^{ct} f(t)$	$F(s-c)$	30. $t^n f(t), n=1,2,3,\dots$	$(-1)^n F^{(n)}(s)$
31. $\frac{1}{t} f(t)$	$\int_s^\infty F(u) du$	32. $\int_0^t f(v) dv$	$\frac{F(s)}{s}$
33. $\int_0^t f(t-\tau) g(\tau) d\tau$	$F(s)G(s)$	34. $f(t+T) = f(t)$	$\frac{\int_0^T e^{-st} f(t) dt}{1-e^{-sT}}$
35. $f'(t)$	$sF(s) - f(0)$	36. $f''(t)$	$s^2F(s) - sf(0) - f'(0)$
37. $f^{(n)}(t)$	$s^n F(s) - s^{n-1} f(0) - s^{n-2} f'(0) - \dots - sf^{(n-2)}(0) - f^{(n-1)}(0)$		

Problem 3. (40 points) For the following block diagram of a control system, show analytically the values of K for which the system is stable or ... show analytically there are no values of K for which the system will be stable.

